

INVACARE MOBILITY

# Scooters



CATALOGUE



Yes, you can.®

Making Life's  
Experiences Possible



# Contents

Free 24 Hour Roadside Assistance .....	3
Colibri .....	4
Leo .....	6
Pegasus Metro .....	8
Pegasus Pro .....	10
Comet Pro (NZ Only) .....	12
Comet Alpine+ .....	14
Comet Ultra .....	16
Accessories .....	18



# Keeping you moving

# Free 24 Hour Roadside Assist

## New Zealand



### AA help is at hand 365 days of the year

Invacare has joined up with the people at AA Roadservice cover to bring you Peace of mind. With any Invacare mobility scooter purchase, you will receive 24 hour, 365 days per year, roadside assistance, for three years, FREE! So not only can you enjoy all the great features offered by our range of mobility scooters, you can rest assured knowing that if anything goes wrong with your mobility scooter, help is just an 0800 number away.

### How do I become eligible for the 3 years FREE offer?

Simple. If you purchase any Invacare mobility scooter, you need to ensure your Invacare approved dealer registers for your warranty online at the time of purchase\*. Once your dealer has registered for your warranty, you will be automatically signed up for the program and can call 0800 500 222 any time you need to!



## Australia



### 24/7 Road Service Australia

Invacare offers 1 year free breakdown assistance when you purchase your new scooter. To qualify for roadside assistance customers need to have current and active policies with 24/7 Road Service Australia.

Roadside assistance provides assistance only when:

- Customer has active policy
- Broken down (Mechanical Breakdown ONLY) outside of home

Roadside assistance provides a towing service to bring the scooter home for the customer. We do not offer repairs, we do not do maintenance nor offer assistance of any kind when customer are located in their home.

To be eligible you need to ensure your Invacare approved dealer registers your warranty online at the time of purchase. Once your dealer has registered your warranty, you will be automatically signed up for cover and can call 1300 550 279 any time you need to!

For further information ring 24/7 Road Services Australia on 1300 550 279.



Yes, you can.®

Making Life's Experiences Possible



# Colibri

THE COLOURFUL ROUTE TO  
EFFORTLESS, SAFE DRIVING



The Invacare Colibri is a stylish, simple and colourful micro lightweight scooter, designed for those who enjoy a totally independent lifestyle. Less than a minute is all that's needed to disassemble the Colibri for transportation.



# Colibri



Thanks to the unique patented Invacare LiteLock™ system the scooter can easily be taken apart without the need for tools and fits neatly into any car boot. Plus, with its small footprint the Invacare Colibri offers greater manoeuvrability in tight, or limited spaces.

Additionally, you can choose from a range of trendy colour panels to match your style, swapping them according to your needs.

Choose where to charge your battery: directly on the Colibri or detached from it.

The soft, padded seat provides comfort during driving. For increased comfort there is also the optional 'easy fit' seat suspension kit.

## Features













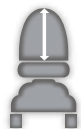
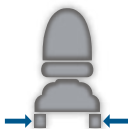



Effortless dismantling can be done in less than a minute for transportation.



A soft padded seat provides additional comfort

## Tech Specs

 <p><b>Backrest width</b> 465 mm</p>	 <p><b>Seat depth</b> 400 mm</p>	 <p><b>Floor to seat height</b> 370 - 420 mm</p>	 <p><b>Backrest height</b> 385 mm</p>	 <p><b>Driving unit width</b> 505 mm</p>	 <p><b>Total length</b> 1010 mm</p>	 <p><b>Empty weight</b> 49 kg (18 Ah)</p>	 <p><b>Max user weight</b> 136 kg</p>
 <p><b>Battery capacity</b> 2 x 18 Ah</p>	 <p><b>Turning diameter</b> 2200 mm</p>	 <p><b>Max climbable obstacle height</b> 45 mm</p>	 <p><b>Ground clearance</b> 50mm</p>	 <p><b>Max safe slope</b> 6° / 10.5°</p>	 <p><b>Max driving distance</b> Up to 16 km</p>	 <p><b>Max driving speed</b> 8 km/h</p>	 <p><b>Motor capacity</b> 200 W</p>

\* Warranty Terms and Conditions apply. Contact Invacare for full details.



**Making Life's Experiences Possible**

# Leo

SOLID, SAFE, SECURE



Safety is a key feature of the Leo, but this does not detract from its stylish and sporty looks. Leo offers users the freedom and confidence to enjoy their essential daily outings and leisure excursions. With high standards of design and safety engineering, the Leo undoubtedly sets a new market standard.





# Leo



The Invacare Leo offers a smooth, safe drive in a scooter that is easy to control and manoeuvre. The Leo intelligent lighting package includes indicators that automatically switch off and a rear brake light for safe driving. In addition to a visual warning for the battery level display, users are also alerted with an audible warning (beep) when the battery needs recharging.

The Leo is a compact mini-scooter that can be easily dismantled for transportation during longer trips or weekend breaks. With a smooth drive and easy manoeuvrability, getting around tight corners in the local shopping centre, museum or leisure complex becomes refreshingly easy. Access to the battery and electronics for maintenance or servicing is much easier with the Leo as only one part needs to be removed.

## Features



Users can easily adjust the tiller to suit their needs.



Rear brake lighting warns other people that the scooter is slowing down, thus preventing collisions.















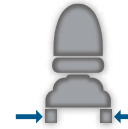



Swivel functionality and sliding rails ensure optimal seating position.



This unique two-step disengaging lever prevents the scooter from accidentally freewheeling.

## Tech Specs

 <b>Backrest width</b> 470 mm	 <b>Seat depth</b> 410 mm	 <b>Floor to seat height</b> 460 - 560 mm	 <b>Backrest height</b> 475 mm	 <b>Driving unit width</b> 590 mm	 <b>Total length</b> 1220 mm	 <b>Empty weight</b> 59 kg (exc batteries) 83 kg (inc batteries)	 <b>Max user weight</b> 136 kg
 <b>Battery capacity</b> 2 x 12V/36Ah	 <b>Turning diameter</b> 2620 mm	 <b>Max climable obstacle height</b> 60 mm	 <b>Ground clearance</b> 70 mm	 <b>Max safe slope</b> 10°	 <b>Max driving distance</b> 38 km	 <b>Max driving speed</b> 8 km/h	 <b>Motor capacity</b> 240 W

\* Warranty Terms and Conditions apply. Contact Invacare for full details.



Yes, you can.®

Making Life's Experiences Possible

# Pegasus Metro

THE PERFECT MIX OF COMFORT, SAFETY AND RELIABILITY



The ergonomically designed Pegasus METRO has been designed from the ground up to focus on key aspects important to both new and seasoned scooter users. As a result, it is equipped with numerous features to ensure users experience a safe, easy and enjoyable ride.





# Pegasus Metro



The suspension system on the compact Pegasus METRO has been designed to navigate a variety of everyday surfaces and terrains, allowing you to relax and enjoy a controlled, sturdy drive in comfort.

In addition to a unique lighting system, the Pegasus METRO is equipped with an electronic speed reduction feature that automatically reduces speed around bends, ensuring safe, comfortable manoeuvres at all times. Furthermore, a two-step disengaging lever prevents the scooter from free-wheeling if it is knocked out of drive mode.

Electronics and the motor are protected from corrosion and water which safeguard the vital workings of the scooter against dirt preventing any unnecessary malfunctions.

## Features



Users can easily adjust the tiller with a lever to suit their needs.



Ergonomically designed steering system makes for easier, more responsive control.



Ensures immediate braking if required.













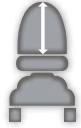
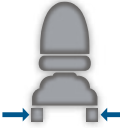



Clear, bright brake lighting warns people that the scooter is slowing down.



Dashboard configuration.

## Tech Specs

 <b>Backrest width</b> 510 mm	 <b>Seat depth</b> 470 mm	 <b>Floor to seat height</b> Min. 440 mm Max. 510 mm	 <b>Backrest height</b> 490mm	 <b>Driving unit width</b> 660 mm	 <b>Total length</b> 1270 mm	 <b>Empty weight</b> 110 kg	 <b>Max user weight</b> 136 kg
 <b>Battery capacity</b> 2 x 12 V/50 Ah	 <b>Turning diameter</b> 2600 mm	 <b>Max climable obstacle height</b> 80 mm	 <b>Ground clearance</b> 78 mm	 <b>Max safe slope</b> 6°	 <b>Max driving distance</b> 54 km	 <b>Max driving speed</b> 10 km/h	 <b>Motor capacity</b> 240 w / 600 w

\* Warranty Terms and Conditions apply. Contact Invacare for full details.



**Making Life's Experiences Possible**

# Pegasus Pro

COMFORT, SAFETY AND RELIABILITY WITH ADDED PERFORMANCE



With enhanced battery performance, superior suspension and large 12" wheels, the Pegasus PRO is ideal for users who need that extra performance. comfort, safety and reliability features to make it the ideal choice for users who demand more.





# Pegasus Pro



The advanced suspension system on the Pegagus PRO has been designed to bring better performance and give a smoother ride over a variety of surfaces and terrains. In addition, the Pegagus PRO features a powerful motor and 12" pneumatic tyres to ensure that whether you are in the city or the country, you get where you need to go in comfort and style.

An on-board electronic speed reduction system automatically reduces speed around bends, ensuring users are confidently making safe, comfortable manoeuvres. Furthermore, a two-step disengaging lever prevents the scooter from free-wheeling if it is knocked out of drive mode.

The electronics and motor have additional protection to guard against water and corrosion, safeguarding the vital workings of the scooter against any unnecessary malfunctions.

## Features



Users can easily adjust the tiller with a lever to suit their needs.



Ergonomically designed steering system makes for easier, more responsive control.



Ensures immediate braking if required.















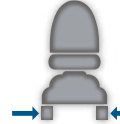



Clear, bright brake lighting warns people that the scooter is slowing down.



Dashboard configuration.

## Tech Specs

 <p><b>Backrest width</b> 510 mm</p>	 <p><b>Seat depth</b> 470 mm</p>	 <p><b>Floor to seat height</b> Min. 440 mm Max. 510 mm</p>	 <p><b>Backrest height</b> 490mm</p>	 <p><b>Driving unit width</b> 650 mm</p>	 <p><b>Total length</b> 1320 mm</p>	 <p><b>Empty weight</b> 136 kg</p>	 <p><b>Max user weight</b> 160 kg</p>
 <p><b>Battery capacity</b> 2 x 12 V/75 Ah</p>	 <p><b>Turning diameter</b> 2750 mm</p>	 <p><b>Max climbable obstacle height</b> 100 mm</p>	 <p><b>Ground clearance</b> 100 mm</p>	 <p><b>Max safe slope</b> 10°</p>	 <p><b>Max driving distance</b> 52 km</p>	 <p><b>Max driving speed</b> 10 km/h</p>	 <p><b>Motor capacity</b> 550 W / 1300 W</p>

\* Warranty Terms and Conditions apply. Contact Invacare for full details.



**Making Life's Experiences Possible**

# Comet Pro

POWER AND PERFORMANCE IN A PREMIUM PACKAGE

ONLY AVAILABLE  
IN NEW ZEALAND



Whether you're popping to the local shops, taking longer trips into town, or looking to go further afield, the new Comet Pro will take you the distance in comfort, safety and style. Its powerful outdoor capabilities, combined with advanced safety features and options, ensures a speedy, powerful and reliable drive.





# Comet Pro



Large 13" front and rear wheels, combined with a superior suspension system, allows the safe negotiation of kerbs and obstacles in a smooth and comfortable manner. Additionally, the automatic speed reduction will slow you down when driving around corners at high speed for additional stability and safety.

Advanced safety features, such as a two step disengaging lever and automatic speed reduction, offers additional peace of mind wherever you go.

The Comet Pro offers exceptional manoeuvrability and control, even through tight and challenging spaces. Additionally, the ergonomic steering ensures an optimal driving position, allowing for a more enjoyable and relaxing journey.

## Features



Advanced suspension for a smooth and comfortable drive over rugged terrain.



Easy drive direction stability keeps you in a straight line at high speeds for additional safety and stability.















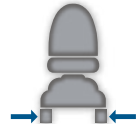



Two step disengaging lever prevents the scooter from accidentally free-wheeling.



Automatic speed reduction reduces speed around bends for added safety.

## Tech Specs

 <b>Backrest width</b> 510 mm	 <b>Seat depth</b> 470mm	 <b>Floor to seat height</b> Min. 440 mm Max. 510 mm	 <b>Backrest height</b> 490mm	 <b>Driving unit width</b> 665 - 685 mm	 <b>Total length</b> 1450 mm	 <b>Empty weight</b> 136 kg	 <b>Max user weight</b> 160 kg
 <b>Battery capacity</b> 2 x 12 V/75 Ah	 <b>Turning diameter</b> 2750 mm	 <b>Max climable obstacle height</b> 100 mm	 <b>Ground clearance</b> 100 mm	 <b>Max safe slope</b> 10°	 <b>Max driving distance</b> 55 km	 <b>Max driving speed</b> 15 km/h	 <b>Motor capacity</b> 550 W / 1600 W

\* Warranty Terms and Conditions apply. Contact Invacare for full details.



Making Life's Experiences Possible

# Comet Alpine+

CHALLENGE THE OUTDOORS WITH POWER, CONTROL AND STABILITY



For those who enjoy adventures across terrains too challenging for a traditional scooter, the Comet® Alpine+ offers the perfect solution. Its robust and powerful driving characteristics gives you the freedom to discover the great outdoors with minimal effort in continuous comfort and safety.





# Comet Alpine+



As part of the Comet family, the Comet Alpine+ comes packed with all of its well-known safety features and customisation capabilities, offering a reliable, powerful and stylish scooter.

- Powerful and robust
- Excellent outdoor capabilities
- Safety at its core

The Comet Alpine+ offers excellent maneuverability and power without compromising safety and style. Thanks to its powerful motors and superior suspension system, the Comet Alpine+ lets you challenge the great outdoors with minimal effort and complete control.

Vital components are protected from water and dirt thanks to the in-built anti splash guards. Directional stability keeps you moving in a straight line and automatic speed reduction to slow you down when driving round corners.

## Features



LCD dashboard for clear, easy to read information.



Seat suspension module offers additional comfort by adding an optional seat suspension.













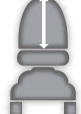
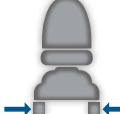



Seat riser electronically increase the seat height to achieve a preferred driving height.



An optional off board charger allows you to conveniently charge the batteries away from the scooter.

## Tech Specs

 <b>Backrest width</b> 510 mm	 <b>Seat depth</b> 460 mm	 <b>Floor to seat height</b> Min. 440 mm Max. 510 mm	 <b>Backrest height</b> 630 mm	 <b>Driving unit width</b> 665 - 685 mm	 <b>Total length</b> 1450 mm	 <b>Empty weight</b> 143 kg	 <b>Max user weight</b> 160 kg
 <b>Battery capacity</b> 2 x 12 V/75 Ah	 <b>Turning diameter</b> 2750 mm	 <b>Max climbable obstacle height</b> 100 mm	 <b>Ground clearance</b> 100 mm	 <b>Max safe slope</b> 10°	 <b>Max driving distance</b> 58 km	 <b>Max driving speed</b> 10 km/h	 <b>Motor capacity</b> 650 W / 1800 W

\* Warranty Terms and Conditions apply. Contact Invacare for full details.



Yes, you can.®

Making Life's Experiences Possible

# Comet Ultra

**BUILT TO SUPPORT WITH PERFORMANCE  
AND RELIABILITY**



Ideal for those with larger body shapes, the Comet® Ultra offers a secure, supportive and powerful driving experience without compromising on style or functionality. The Comet Ultra will get you to your destination quickly and efficiently, in complete comfort and control.





# Comet Ultra



The safety and stability of the Comet Ultra is never a concern; even for users weighing up to 220kg. Developed with the highest quality components and safety features, the Comet Ultra makes a trustworthy companion no matter where you go. Furthermore, its flexibility and adaptability means you can customise your scooter to suit your unique style and individual preference.

The special contoured Ultra Seat has been developed in conjunction with therapists to ensure an optimum seating position and increased comfort. In addition, a pneumatically adjustable lumbar support allows for further comfort when seated if and when required. The reinforced seat base and adjustable armrests offer excellent support and allows the use of the armrest as additional support when getting on and off the scooter.

## Features



Improved suspension to offer superior comfort to larger individuals.















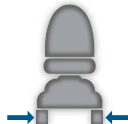



Reinforced seat column offers additional stability and safety when seated.



Reinforced height and width adjustable armrest.

## Tech Specs

 <p><b>Backrest width</b> 660 mm</p>	 <p><b>Seat depth</b> 535 mm</p>	 <p><b>Floor to seat height</b> Min. 440 mm Max. 510 mm</p>	 <p><b>Backrest height</b> 515 mm</p>	 <p><b>Driving unit width</b> 665 - 685 mm</p>	 <p><b>Total length</b> 1450 mm</p>	 <p><b>Empty weight</b> 148 kg</p>	 <p><b>Max user weight</b> 220 kg</p>
 <p><b>Battery capacity</b> 2 x 12 V/75 Ah</p>	 <p><b>Turning diameter</b> 2750 mm</p>	 <p><b>Max climbable obstacle height</b> 100 mm</p>	 <p><b>Ground clearance</b> 100 mm</p>	 <p><b>Max safe slope</b> 10°</p>	 <p><b>Max driving distance</b> 49 km</p>	 <p><b>Max driving speed</b> 10 km/h</p>	 <p><b>Motor capacity</b> 650 W / 1800 W</p>

\* Warranty Terms and Conditions apply. Contact Invacare for full details.





Yes, you can.®

Making Life's Experiences Possible

# Accessories: Driving Comfort

Part No.	Description	Comet	Pegasus	Leo	Colibri
	<b>Seat suspension</b> A seat suspension kit adds extra comfort during driving.				
	<b>Suspension</b> <b>Height</b>				
SP1577212	Low 425mm up to 100kg				✓
SP1577213	Medium 450mm up to 100kg				✓
SP1577214	High 475mm up to 100kg				✓
1522456	Low 478.5mm up to 100kg		✓		
1522457	Medium 503.5mm up to 100kg		✓		
1522458	High 528.5mm up to 100kg		✓		
SP1541627	Low 510mm up to 100kg			✓	
SP1541628	Medium 535mm up to 100kg			✓	
SP1541629	High 560mm up to 100kg			✓	
SP1528986	Low 508.5 up to 100kg	✓			
SP1528987	Medium 533.5 up to 100kg	✓			
SP1528988	High 558.5 up to 100kg	✓			
1522459	Low 508.5mm up to 160kg to suit Comet HD	✓			
1522460	Medium 533.5mm up to 160kg to suit Comet HD	✓			
1522461	High 558.5mm up to 160kg to suit Comet HD	✓			
	<b>Electric seat riser</b> Electronically raises the seat up to the preferred height. Lifts up to 120mm. (N/A for Comet HD)	✓			
SP1521980					
375000-68600	<b>Sun canopy</b> Add the sun shade when needed.	✓	✓	✓	
					
SP1543160	<b>Wind screen</b> Offers protection from the wind.	✓	✓	✓	
					

# Accessories: Storage

1505731	<b>Storage Bag with Invacare Logo</b> This spacious bag offers extra storage room.		✓		
					
1637910	<b>Lockable storage box</b> Keeps your valuables secure while driving; box can be mounted in the front or rear of the scooter. (SP1552537 bracket required to fit storage box to the rear. No bracket required for front mounting)	✓	✓	✓	
					
1637913	Rear lockable storage box (mounting bracket included)	✓	✓		
1505727	<b>Rear basket</b> Used to store your extra shopping.	✓	✓	✓	✓
SP1577430	<b>Front basket</b> (plastic)	✓	✓	✓	✓
SP1637915	<b>XL Front basket</b> (plastic)	✓	✓		
					



# Accessories: Maintenance

Part No.	Description		Comet	Pegasus	Leo	Colibri
1509434	<b>Storage cover</b> Protects your scooter from dirt and wet conditions.				✓	✓
SP1518240			✓	✓		

# Accessories: Carriers

SP1553851	<b>Rollator carrier</b> The rollator carrier is adjustable to carry your rollator safely.		✓	✓	✓	
1505728	<b>Walking frame carrier</b> Keeps your walking frame stable during the drive.		✓	✓	✓	
SP1521594	<b>Cup holder</b> Stores bottles or soft drinks; can be folded up when not in use.		✓	✓	✓	
1572971	<b>Oxygen bottle carrier</b> Securely stores your oxygen during driving.				✓	✓
1505729			✓	✓		
1528274	<b>Cane and crutch holder</b> Keeps your cane/crutch stable during driving. *Must order SP1577455 when using with Colibri		✓	✓	✓	✓*
1637912	<b>Mobile phone holder</b> Keeps your phone hands-free while driving.		✓	✓	✓	✓

# Accessories:

SP1541502	<b>Extension Tube</b> Use the extension bracket when mounting accessories in the seat receiver.		✓	✓		
SP1577455	<b>Accessory Bracket</b> Use the bracket when mounting accessories in the seat receiver.					✓
SP1552537	<b>Rear Bracket for Storage Box</b> Use the front basket for your shopping and mount the storage box behind your seat using this bracket.		✓	✓	✓	
SB02	<b>Single Bracket Accessory</b> 2:1 Adapter that allows single stem accessories be fitted to a twin stem seat mount.		✓	✓	✓	
1637917	<b>USB Charger</b>		✓	✓		
1637912	<b>Mobile Phone Holder</b>					



Yes, you can.®

Making Life's Experiences Possible

# Accessories: Safety Options

Part No.	Description		Comet	Pegasus	Leo	Colibri
1509362 SP1518274	<b>Seat belt</b> Keeps you well positioned in the seat at all times.		✓	✓	✓	✓
	<b>Steel bumpers</b> Protect the Scooter shrouds from scratches and bumps.					
1638965	Front bumper, Pegasus 4w			✓		
1528298	Front bumper, Comet 4w		✓			
1638966	Rear bumper, Pegasus 4w			✓		
1638967	Rear bumper, Comet 4w		✓			
SP1521592	<b>Safety vest</b> Enhances your visibility to others.		✓	✓	✓	✓
SP1543153 SP1543154	<b>Personal key</b> For extra safety choose a personal key cylinder for your scooter, available with 2 personal keys.		✓	✓	✓	✓
SP1518241	<b>Large mirrors</b> Improve your safety - can be mounted left or right.		✓	✓	✓	
1637911	<b>Deluxe mirrors</b> Larger mirrors for your Pegasus or Comet		✓	✓		

## Colour Options:

### Colibri:



### Leo:



### Pegasus Metro, Pegasus Pro, Comet Pro, Comet Alpine +, Comet Ultra:

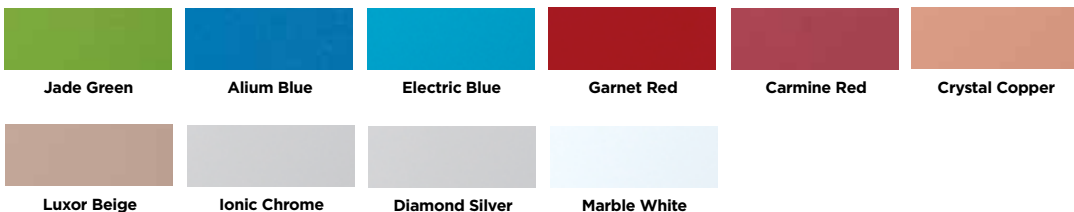

Whatever your final choice, enjoy the freedom and confidence of being able to get around comfortably and securely.

Find out more about our Scooter Range at [www.invacare.com.au](http://www.invacare.com.au) or [www.invacare.co.nz](http://www.invacare.co.nz). Our Scooter Range offers you the perfect solution for every excursion or adventure. Imagine being able to take long journeys in complete safety and comfort.

FOR FURTHER INFORMATION:

**New Zealand:** Freephone 0800 468 222, email [sales@invacare.co.nz](mailto:sales@invacare.co.nz) or visit [www.invacare.co.nz](http://www.invacare.co.nz)

**Australia:** Freephone 1800 460 460, email [orders@invacare.com.au](mailto:orders@invacare.com.au) or visit [www.invacare.com.au](http://www.invacare.com.au)

All rights reserved. All information quoted is believed to be correct at time of publication. Invacare reserves the right to alter product specifications without prior consent. 06/2024



Yes, you can.®