

# Pegasus Pro

COMFORT, SAFETY AND RELIABILITY WITH ADDED PERFORMANCE



With enhanced battery performance, superior suspension and large 12" wheels, the Pegasus PRO is ideal for users who need that extra performance. comfort, safety and reliability features to make it the ideal choice for users who demand more.



Yes, you can.®

Making Life's Experiences Possible

# Pegasus Pro



The advanced suspension system on the Pegasus PRO has been designed to bring better performance and give a smoother ride over a variety of surfaces and terrains. In addition, the Pegasus PRO features a powerful motor and 12" pneumatic tyres to ensure that whether you are in the city or the country, you get where you need to go in comfort and style.

An on-board electronic speed reduction system automatically reduces speed around bends, ensuring users are confidently making safe, comfortable manoeuvres. Furthermore, a two-step disengaging lever prevents the scooter from free-wheeling if it is knocked out of drive mode.

The electronics and motor have additional protection to guard against water and corrosion, safeguarding the vital workings of the scooter against any unnecessary malfunctions.

## Features



Users can easily adjust the tiller with a lever to suit their needs.



Ergonomically designed steering system makes for easier, more responsive control.



Ensures immediate braking if required.















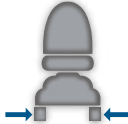



Clear, bright brake lighting warns people that the scooter is slowing down.



Dashboard configuration.

## Tech Specs

 <b>Backrest width</b> 510 mm	 <b>Seat depth</b> 470 mm	 <b>Floor to seat height</b> Min. 440 mm Max. 510 mm	 <b>Backrest height</b> 490mm	 <b>Driving unit width</b> 650 mm	 <b>Total length</b> 1320 mm	 <b>Empty weight</b> 136 kg	 <b>Max user weight</b> 160 kg
 <b>Battery capacity</b> 2 x 12 V/75 Ah	 <b>Turning diameter</b> 2750 mm	 <b>Max climbable obstacle height</b> 100 mm	 <b>Ground clearance</b> 100 mm	 <b>Max safe slope</b> 10°	 <b>Max driving distance</b> 52 km	 <b>Max driving speed</b> 10 km/h	 <b>Motor capacity</b> 550 W / 1300 W

## Colour Options

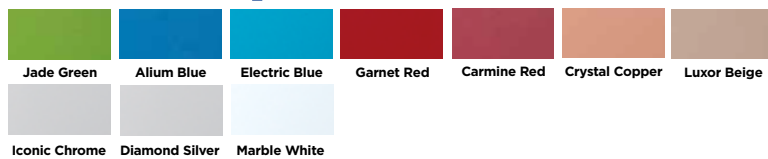

\* Warranty Terms and Conditions apply. Contact Invacare for full details.

FOR FURTHER INFORMATION:

**New Zealand:** Freephone 0800 468 222, email [sales@invacare.co.nz](mailto:sales@invacare.co.nz) or visit [www.invacare.co.nz](http://www.invacare.co.nz)

**Australia:** Freephone 1800 460 460, email [orders@invacare.com.au](mailto:orders@invacare.com.au) or visit [www.invacare.com.au](http://www.invacare.com.au)

All rights reserved. All information quoted is believed to be correct at time of publication. Invacare reserves the right to alter product specifications without prior consent. 03/2025



**Yes, you can.®**